



CRANE FORKS

Features

Features of the crane forks:

- From 1500 - 3000 kg capacity
- Fully Self Levelling
- Adjustable Height and Forks

All our products are powder-painted with RAL color 7035. Hot-dip galvanized coating is also available on request. We meet all European Directives and ASME Standards.

[REQUEST A QUOTE >](#)

Description

This model of lifting fork features an internal spring mechanism for an automatic load balancing.

The pins are 1000 mm long but can be requested of 1200 mm too. The fork comes with a safety belt.

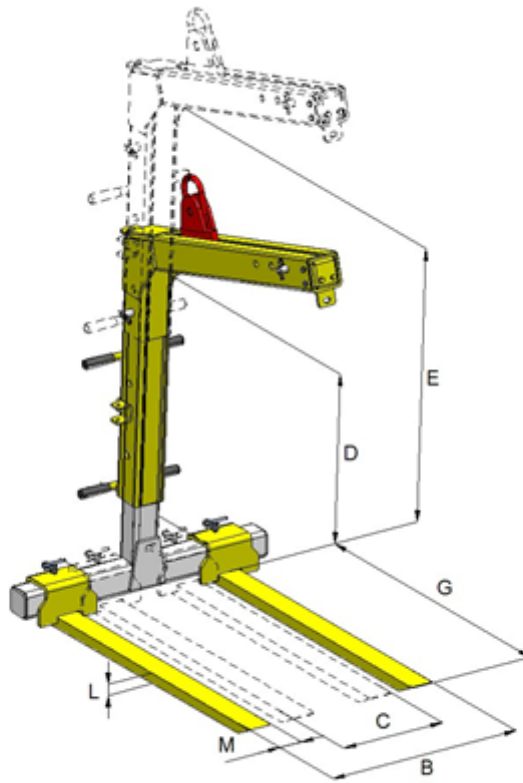

MODEL	DIMENSIONS (mm)				WEIGHT kg	WLL kg
	C-B	D-E	G	L-M		
15.09.19	350 - 950	1154 - 1705	1000	30X90	150	1500
15.09.21	370 - 960	1154 - 1703	1000	35X100	180	2000
15.09.23	400 - 980	1279 - 1828	1000	40X90	230	2500
15.09.24	360 - 980	1279 - 1828	1000	35X120	250	3000

MODEL	DIMENSIONS (mm)				WEIGHT kg	WLL kg
	C-B	D-E	G	L-M		
15.09.19.P12	350 - 950	1150 - 1700	1200	35X100	195	1500
15.09.21.P12	370 - 960	1150 - 1700	1200	35X120	210	2000
15.09.23.P12	400 - 980	1280 - 1830	1200	40X90	270	2500

15.09.24.P12	360 - 980	1280 - 1830	1200	50X120	315	3000
--------------	-----------	----------------	------	--------	-----	------